

100 Series AFCO-Rail Fixed Stair Rail









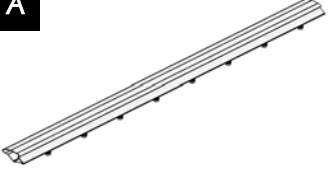

INSTALLATION INSTRUCTIONS

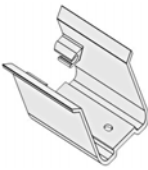
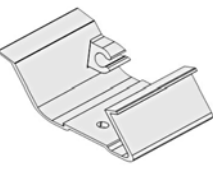

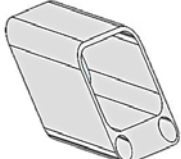
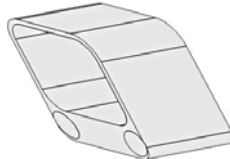
AFCO
Columns and Railings
a Division of AFCO Industries, Inc.

PARTS INCLUDED:

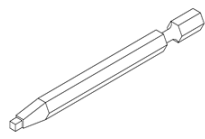
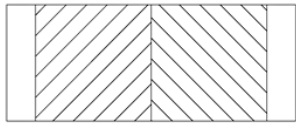
TOP RAIL WITH CONNECTORS (1)	BOTTOM RAIL WITH CONNECTORS (1)	UPPER SADDLE BRACKET (1)	LOWER SADDLE BRACKET (1)
A 	B 	C 	D 
BRACKET COVERS (2)	UPPER BOTTOM BRACKET (1)	LOWER BOTTOM BRACKET (1)	10" SUPPORT BLOCK (1)
E 	F 	G 	H 
SUPPORT BLOCK CONNECTOR (2)	#10 SELF DRILLING SCREWS	3 1/2" SQUARE DRIVER BIT (1)	ADHESIVE TAB (1)
I 	J 1" - 4 each 1-1/2" - 8 each 	K 	L 

100 SERIES AFCO-RAIL FIXED STAIR RAIL

TOOLS REQUIRED:

Drill bit 5/32" (.156")
Drill (with adjustable clutch, recommended)
Miter Saw (with metal cutting blade)
Level
Rubber mallet
Tape measure
Touch-up paint

NOTES:

- Post and balusters packaged separately.
- An AFCO-Tool is available to simplify the locating, pre-drilling and installation of brackets.

FOR A SUCCESSFUL INSTALLATION:

- Read the instructions completely before beginning the installation.
- Plan your railing project. Sketch your project with the actual measurements of your deck or balcony complete with post locations.
- Check local building codes to ensure compliance.
- Check carton(s) to determine part count is complete.
- After cutting rails, balusters, or posts, paint exposed metal for maximum protection against the elements.
- Installation is best accomplished with two people.
- Wear personal protection equipment; safety glasses, etc.
- Use care not to over-torque the screws. Pre-drilling is recommended.
- **Provided hardware to install AFCO-Rail is for use with Aluminum AFCO-Rail posts. If installing to other surfaces the installer must acquire the appropriate hardware as needed for proper installation.**

POSTS INSTALLATION:

1. Begin by determining where the top and bottom post will be located. Mark the desired location of the post.
Note: To ensure post location is compatible with railing, prior to securing to the deck surface, place both posts in position, and lay the bottom rail along the stair-nosing from top to bottom adjacent to both post. On the rail side of the post, measure up from the top of the rail and ensure there is a minimum of 34" for the 36" rail height and a minimum of 40" for the 42" rail height to the top of the post. Post location may have to be adjusted to ensure minimum is obtained. Repeat this step for the bottom post.

- For railing mounted 36" high use a 44" post at the bottom of the stairs.
- For railing mounted 42" high use a 54" post at the bottom of the stairs.

For a wooden deck position the post so the fasteners will go into the floor joists, and make sure the decking is firmly attached to the joists at the location of the posts. If necessary, use wood blocking as reinforcement underneath the decking where the posts are located. Fasteners which hold the brackets to the surface should be able to secure to joist or reinforcement braces, into at least 3" of solid wood.



2. When the final position is determined for the post, mark the hole locations of the four 3/8" diameter mounting holes provided on the base and remove the post assembly. Drill the marked locations into the decking and reinforcement using the proper size drill required for the fasteners being used.



3. Remount the post assembly. Insert the appropriate fasteners then secure the base to the deck structure. Make certain the posts are plumb. If the post requires adjustment, add stainless steel washers under the base plate. Do not install the base post trim and post capitals until step 4 of the rail installation.
Note: When installing AFco- Rail Post onto treated wood surface, install the provided ACQ pad that is included in the post kit between the post base and the treated surface.

FIXED RAIL INSTALLATION:

1. Lay the bottom rail (B), with baluster connectors facing up and centered between the posts, on the stair nosing from top to bottom, adjacent to the posts and mark a line on the rail from the inside of each post (1). Also, make a reference mark on the bracket side of both posts at the point where the top of the rail meets the post (2).
Note: This reference mark will be used to locate saddle brackets in step 5.

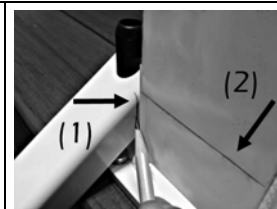

2. Place the top rail (A) next to the bottom rail (B), align the baluster connectors and duplicate the marks from the bottom rail cut line onto the top rail. Now mark the top rail 5/8" shorter on each end; this is the cut line for top rail. Only the top rail is cut 5/8" shorter on each end.









3. Cut the rails along the marked lines.

4. Install the base post trim on the upper and lower posts.

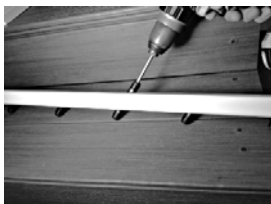
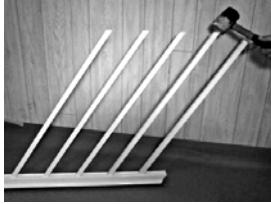
5. To install the saddle bracket (C&D) on both upper and lower post, measure and mark a level line up from the reference marks, previously completed in step 1. Mark 31" for 36" railing or 37" for 42" rail.

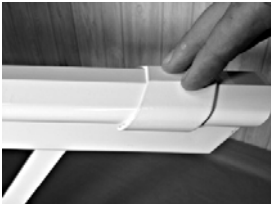

<p>6. Align screw holes in the upper and lower saddle brackets (C&D) on the marked lines. Make sure the brackets are centered on the posts. Mark the screw hole locations with a pencil.</p>	
<p>7. Attach saddle brackets (C&D) with 1-1/2" self-drilling screws (J) at the marked screw locations in Step 6. Pre-drilling is recommended.</p>	
<p>8. Install support block connectors (I) using 1" self-drilling screw (J) to the underside of bottom rail (B). <i>Note: One support block, cut from support block material (H), is recommended for rails measuring 72" in length or less; two support blocks for longer lengths. If one support block is required, install support block connector (I) at center point of bottom rail (B). If two support blocks are required, install support block connectors (I) equal distance from each end of the bottom rail (B).</i></p>	
<p>9. To assemble rail, begin with top rail (A) and insert balusters over pre-installed connectors. Use a rubber mallet to tap the balusters into place. <i>Note: It is recommended to use the box as a pad to prevent scuffing of the painted finish. If installing square balusters, make sure they are properly seated in the slot on the underside of the top rail to prevent twisting.</i></p>	
<p>10. Attach balusters to bottom rail (B) beginning at one end and working to the opposite end. Stand the assembly upside down on the surface of the box and tap the bottom rail with a rubber mallet to secure the balusters in place. Stand assembly upright. <i>Note: Notches are provided on the front of the box to help align balusters and aid in the assembly of the rail in this step.</i></p>	
<p>11. Slide bracket covers (E) at least 3-4" inward over each end of the top rail (A) so the angle of the cover matches the angle of the top rail. <i>Note: A small piece of tape may be required to hold the bracket covers in place.</i></p>	
<p>12. Slide bottom brackets (F&G) with the counter bore holes facing down and toward the balusters, over each end of the bottom rail (B). A small piece of tape may be required to hold lower bottom brackets in place. Next, set the rail assembly into the saddle brackets (C&D) letting the bottom rail hang freely between the posts. <i>Note: May use option (not shown) to install brackets with holes facing up based on customer preference and accessibility.</i></p>	
<p>13. At the point(s) where you installed support block connectors (step 8), carefully measure the distance from the underside of the bottom rail (B) to the floor. Cut support block material (H) to fit. Slip support blocks over support block connectors (I). Slide the rail back into place and make certain the rail is plumb.</p>	

14. Slide and hold the upper bottom bracket (F) firmly against the top post. Secure the bracket with 1-1/2" self-drilling screws (J). Repeat the process securing lower bottom bracket (G) to the bottom post using 1-1/2" self-drilling screws (J).
Note: Screw holes in brackets (F&G) are angled to make mounting the brackets easier.

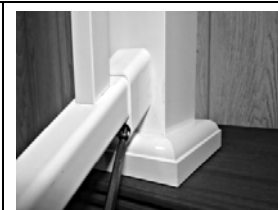

15. Apply adhesive tab (L) to flat, top surface of top rail (A), near the post. Slide bracket covers (E) to interlock with flange on the saddle brackets (C&D).

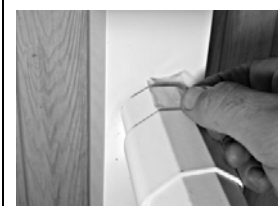

16. Screw 1" self-drilling screws (J) into the top rail (A) from the underside of saddle brackets (C&D) through the provided locating hole.

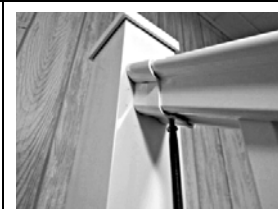

This photo depicts a fully assembled rail section of AFCO-Rail 100 Series Fixed Stair Rail installed between two posts on a standard set of steps.

